

**TOPOGRAPHIC SUPPORT SYSTEM  
PHOTOMECHANICAL SECTION  
MODEL ADC-TSS- 18  
NSN: 3610-01 -105-1556**

Reference TM 5-3610-285-14 and C9100-IL

Intervals and the related man hour times are based on normal operation. The task hour time specified is the time you need to do all the services prescribed for a particular interval. Decrease the interval and lubricate more frequently if your lubricants have been contaminated or you are operating under adverse conditions, including longer-than-usual operating hours. The intervals between lubrications may be extended during periods of low activity, but only if adequate precautions have been taken. The lowest level of maintenance authorized to lubricate a point is indicated by the following symbol: Operator/Crew (C). Clean all fittings, plugs, and caps before removal and/or

lubrication. If possible, exercise moving parts to distribute lubricant evenly. Lubricate all oil can points after washing or fording.

"Reporting errors and recommending improvements. You can help improve this manual. If you find any mistakes or if you know of a way to improve the procedures, please let us know. Mail your letter or DA Form 2028 (Recommended Changes to Publications and Blank forms) direct to: Commander, U.S. Army Troop Support Command, ATTN: AMSTR-MCTS, 4300 Goodfellow Boulevard, St. Louis, Mo. 63120-1798. A reply will be furnished to you

LUBRICANT                      •                      INTERVAL                      •                      LUBRICANT

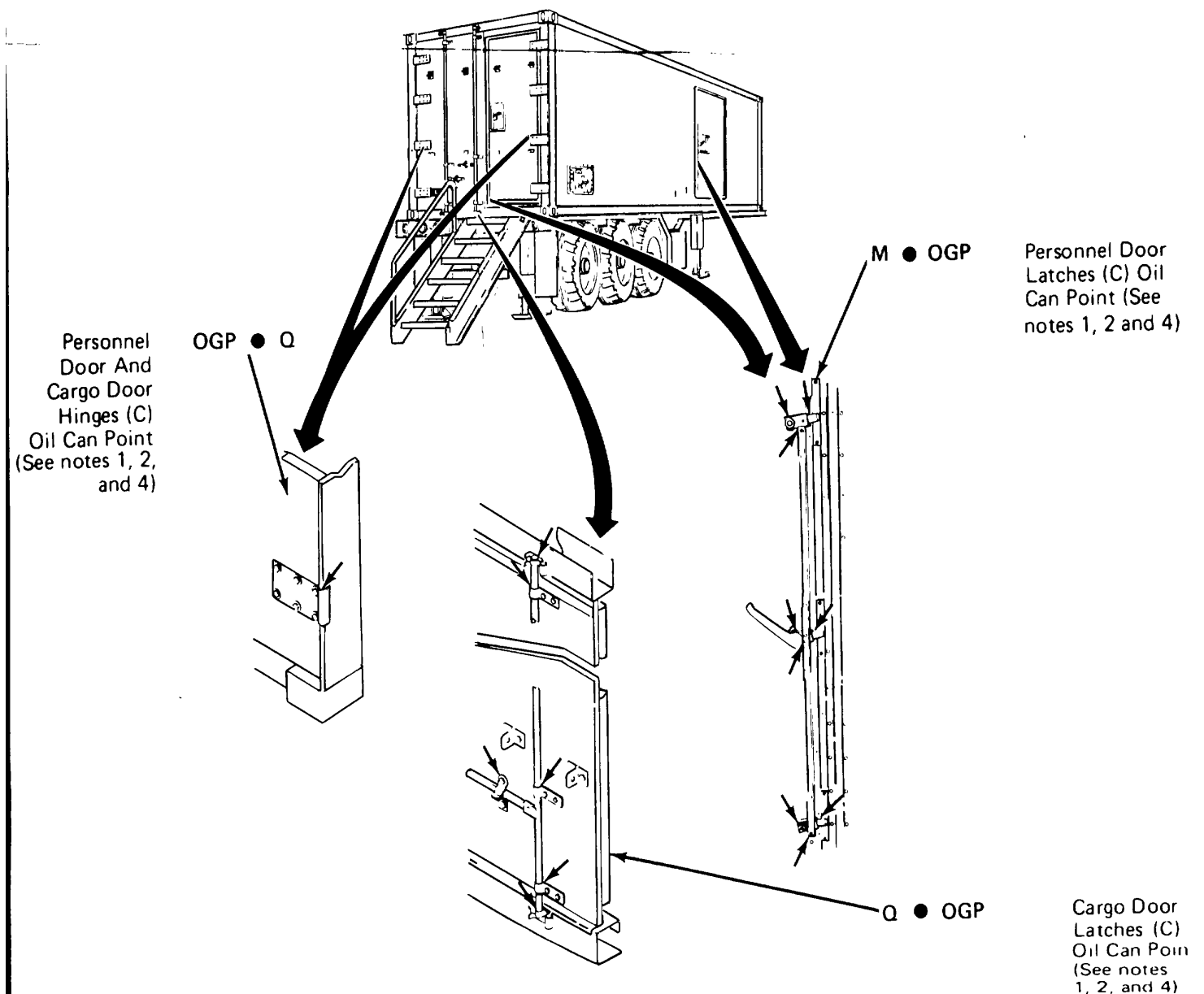

LUBRICANT • INTERVAL

INTERVAL • LUBRICANT

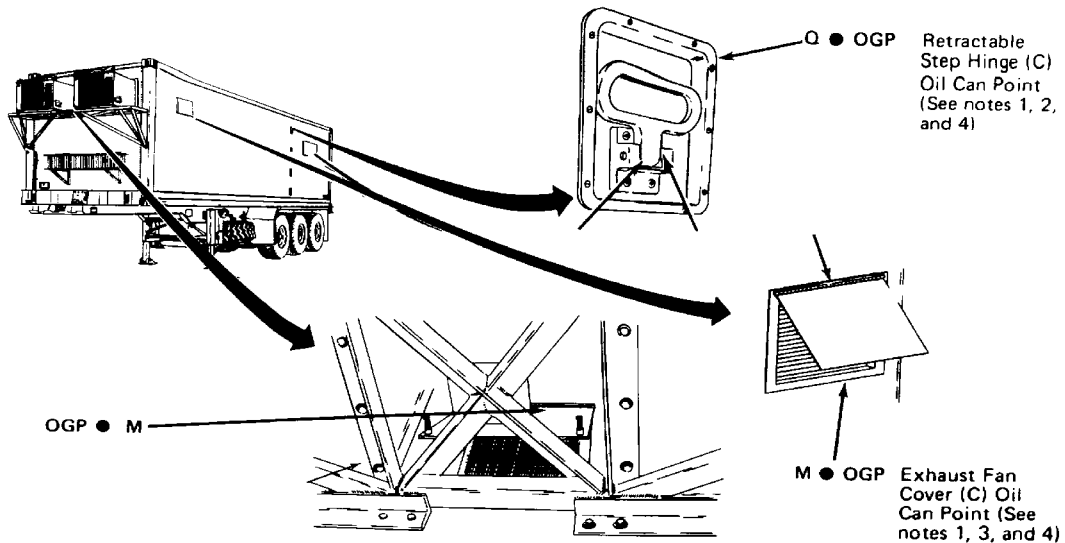

Air Vent Hinge (C) Oil Can Point (See note 4)

TOTAL TASK-HR		TOTAL TASK-HR	
INTERVAL	TASK-HR	INTERVAL	TASK-H R
M	0.3	Q	0.6

KEY

LUBRICANTS	EXPECTED TEMPERATURES	INTERVALS
OGP (MI L-L-7870)	M	MONTHLY
LUBRICATING OIL, GENERAL PURPOSE, LOW TEMPERATURE	Q	QUARTERLY
PERSONNEL DOOR AND CARGO DOOR HINGES	All Temperatures	
PERSONNEL DOOR LATCHES		
CARGO DOOR LATCHES		
RETRACTABLE STEP HINGE		
EXHAUST FAN COVER		
AIR VENT HINGE		

NOTES

- Before lubricating, wipe all points free of dirt, grease, or dust
- Wipe all surplus oil from surfaces after lubrication.
- When lubricating hinges, be sure oil covers entire length of hinge

By Order of the Secretary of the Army:

JOHN A. WICKHAM, JR.  
General, United States Army  
Chief of Staff

Official:

R L. DILWORTH  
Brigadier General, United States Army  
The Adjutant General

DISTRIBUTION:

To be distributed in accordance with DA Form 12--25A. Operator's and Organizational Maintenance requirements for Plate Process Section herein are mandatory; Topographic Support System. Semi trailer Mounted

Copy of this Lubrication Order will remain with the equipment at all times; instructions contained all ties; instructions contained mandatory (10536-2) .

RECOMMENDED CHANGES TO EQUIPMENT TECHNICAL PUBLICATIONS



THEN... JOT DOWN THE DOPE ABOUT IT ON THIS FORM, CAREFULLY TEAR IT OUT, FOLD IT AND DROP IT IN THE MAIL!

**SOMETHING WRONG WITH THIS PUBLICATION?**

FROM: (PRINT YOUR UNIT'S COMPLETE ADDRESS)

DATE SENT

PUBLICATION NUMBER

PUBLICATION DATE

PUBLICATION TITLE

BE EXACT... PIN-POINT WHERE IT IS

PAGE NO.	PARA-GRAPH	FIGURE NO.	TABLE NO.
----------	------------	------------	-----------

IN THIS SPACE TELL WHAT IS WRONG AND WHAT SHOULD BE DONE ABOUT IT:

TEAR ALONG PERFORATED LINE

PRINTED NAME, GRADE OR TITLE, AND TELEPHONE NUMBER

SIGN HERE:

DA FORM 2028-2  
1 JUL 79

PREVIOUS EDITIONS ARE OBSOLETE.

P.S.—IF YOUR OUTFIT WANTS TO KNOW ABOUT YOUR RECOMMENDATION MAKE A CARBON COPY OF THIS AND GIVE IT TO YOUR HEADQUARTERS.

**PIN: 061222-000**